



Make In India

An ISO  
9001 : 2008

CE Mark Products



# SEHGALDOORS



# INTRODUCTION

The values and principles that guide Sehgal Doors were founded by our parent organization – Sehgal & Sehgal

Industries in 1965, started as a Pressed Steel Frames & Furniture manufacturing and development center with a handful of technicians and engineers - to quickly expand and position itself as a market leader.

Sehgal Doors was Set-up as a corresponding business entity in 2007, through our sustained innovation, service-orientation and commitment to deliver nothing but top-notch products.

In just few years, we have established a strong network of sales, service engineers and satisfied customers.

Thus our customer retention rate is among the highest in the industry.

The expanse of our network can be gauged from the fact that we have supplied our entrance industrial houses & Commercial, across the length and breadth of the country.

## COMPANY

The reasons for our spectacular/rapid growth are not difficult to guess. As a family always been able to customize our service to our customer's date their needs. We partner with them, every step of the way in manufacturing doors that are unmatched in:

- Elegance
- Strength
- Utility
- Design

Creating new benchmarks, an exciting range of products the highest level of satisfaction in our team of engineers, designers and door craftsmen. The strength of our doors comes both from the design and the materials used in their fabrication. We design our products to withstand extremes related to:

- Environmental protection against wind, heat, cold, dust
- Security against forced, unauthorized access
- Highest level of safety
- Sound-control
- Fire resistance

Whatever be the nature of your business, Sehgal Doors has a solution to match every need and purpose

## TEAM SEHGAL DOORS

### **A VERY STRONG CHAIN OF COMMITTED EMPLOYEES**

The driving force behind Sehgal Doors exceptional product quality and service is over handsome number of efficient & well-trained employees. Our nationwide Sales, service teams, our employees carry on our proud tradition to delivering 100% customer satisfaction anywhere within the country.

Sehgal Doors was founded with a strong commitment to quality, integrity and service. These principles founded by our principal company are the foundation of Sehgal Doors even today and living with these core values is as essential to our success today, as it was in the past.

# STANDARD PROFILES

## STANDARD PROFILES DOORS

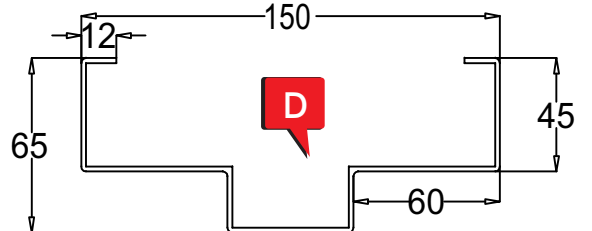
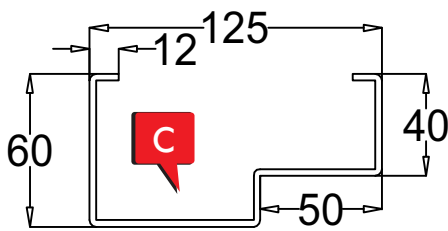
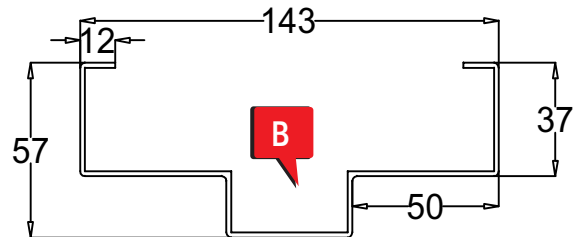
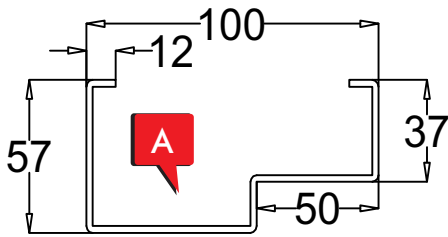

## STANDARD PROFILES PRESSED STEEL

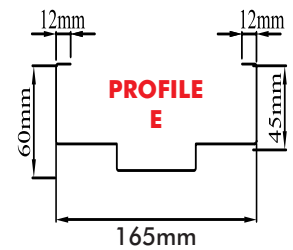
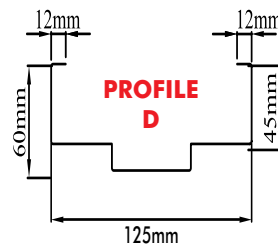
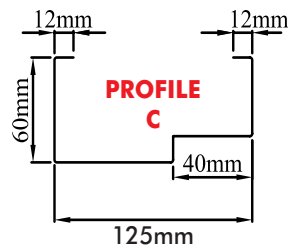
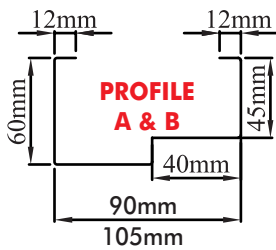

## CUSTOMIZE PROFILE

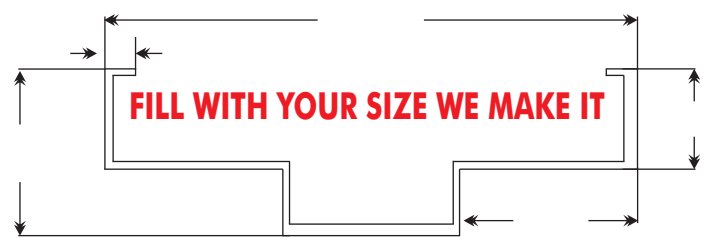
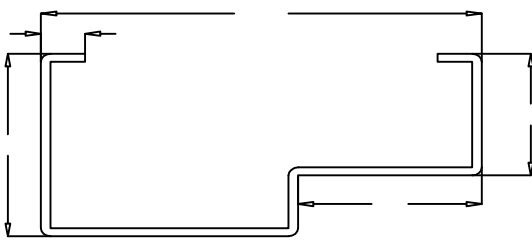

TEXTURE SHADES ALSO AVAILABLE

## COLOURS AVAILABLE



POST OFFICE RED

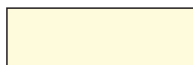

OFF WHITE



DARK GREY



GREY

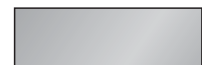

SILVER



F BLUE



DARK BLUE



BROWN



DARK BROWN



BLACK

Note : For any other shade please go through the link & confirm <http://www.ralcolor.com/>

# DIFFERENT STYLES OF DOORS



*BEAUTY & STYLE IS A PART OF QUALITY*

# WHAT IS FIRE DOOR ?

Buildings are compartmentalized to delay the spread of fire from one area to another. These compartments are usually linked by fire doors to allow the flow of traffic around the building. Fire doors have two important functions in a fire; when closed they form a barrier to stop the spread of fire and when opened they provide a means of escape.

A well designed Metal Fire door will delay the spread of fire and smoke without causing too much hindrance to the movement of people and goods.

Every fire door is therefore required to act as a barrier to the passage of smoke and/or fire to varying degrees depending upon its location in a building and the fire hazards associated with that building.

- A fire door required to provide resistance to the passage of a well developed fire must be fitted with intumescent seals. These seals remain dormant under normal conditions but expand greatly in the heat of a fire to close the gap between the door and its frame.
- As smoke spread is an even greater threat to life and property than flames, particularly in the early stages of a fire, fire doors should also be fitted with a 'cold smoke' seal to prevent the ingress of smoke around the door edges. Combined smoke and intumescent seals protect from all aspects of fire in a single unit

## IRON MONGERY / HARDWARE SET

### SINGLE LEAF DOOR

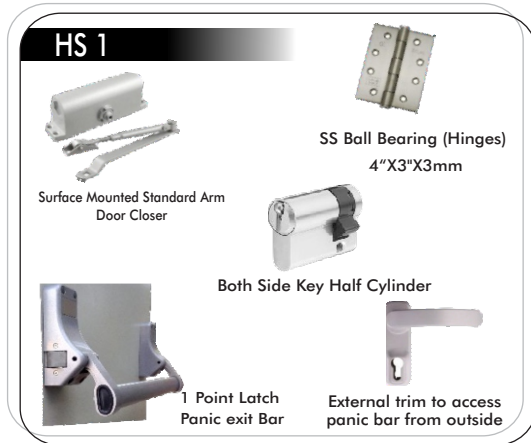

### DOUBLE LEAF DOOR

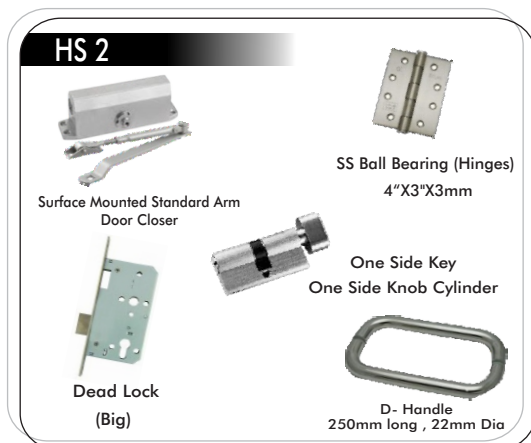
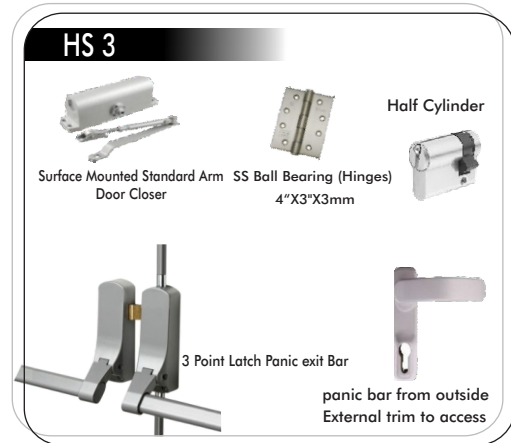



# LIST OF FEW CLIENTS

## GOVERNMENT SECTORS

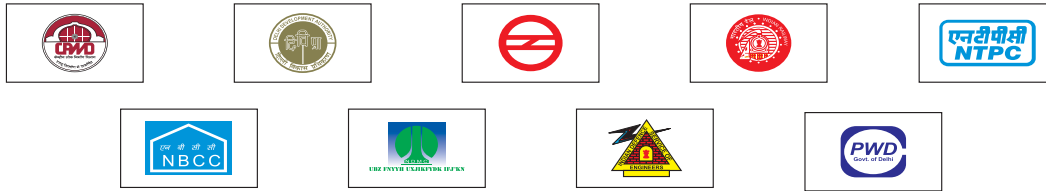

## HOSPITALS



## AUTO-MOBILE INDUSTRIES



## BUILDERS & CONTRACTORS



## CEMENT INDUSTRIES



## LARGE SCALE CORPORATE FIRMS



## HOTELS & MALLS



  
**sehgaldoors**

Work: B-133, Phase-I, Mayapuri Industrial Area, New Delhi-110064  
Phone: +91-11-28114613 | Fax: +91-11-28117907 :  
www.doors.co.in/ E-mail : sehgaldoor@gmail.com



Contact us on  
**9891139441**